

Measuring the wear of some components of the NNPB process:



GALAXY NRP AW1

LMS V1

MEASURING MACHINE FOR NERCK RINGS,
PLUNGERS AND MOULDS

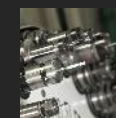

WHO WE ARE



PB / NNPB PROCESS

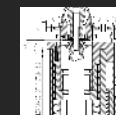

PB / ELEMENTS



GALAXY NRP AW1



LMS V1



FILIPPO MOMBELLI



LUBEN was founded in 1984 with the intention to offer a consulting service on the use of chemicals in glass factories.

The company later devoted itself to the manufacture and supply of variable equipment and plants for the hollow glass industry





WHO WE ARE



PB / NNPB PROCESS

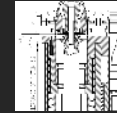

PB / ELEMENTS



GALAXY NRP AW1



LMS V1





Plants & Machines



Variables & Spares



R&D and Sales dept.

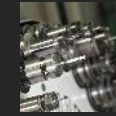

WHO WE ARE



PB / NNPB PROCESS

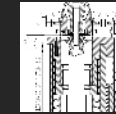

PB / ELEMENTS



GALAXY NRP AW1



LMS V1





My role within the company is the sales of all our products and this allows me to have constant feedback from customers about their needs, requirements and problems



WHO WE ARE



PB / NNPB PROCESS

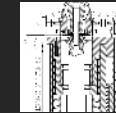

PB / ELEMENTS



GALAXY NRP AW1



LMS V1



Plants & Machines

These machines were born to respond precisely to specific needs of our customers who work with PB and NNPB process; the machines have the function of monitoring the wear of some components of the molding and they are the LMS V1 and the GALAXY line



LMS V1

Mould volume laser
measurement
machine



NRP AW1

Neck rings and
plungers measuring
machine

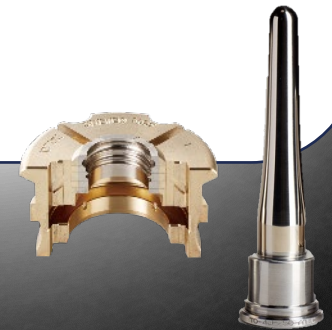

...brief summary

PB PROCESS

We know that one of the glass forming processes is the PB process by which the production capacity of the machine can be increased.

One of the first press-and-blow manufacturing processes was the so-called 62 for large mouth process

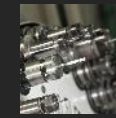
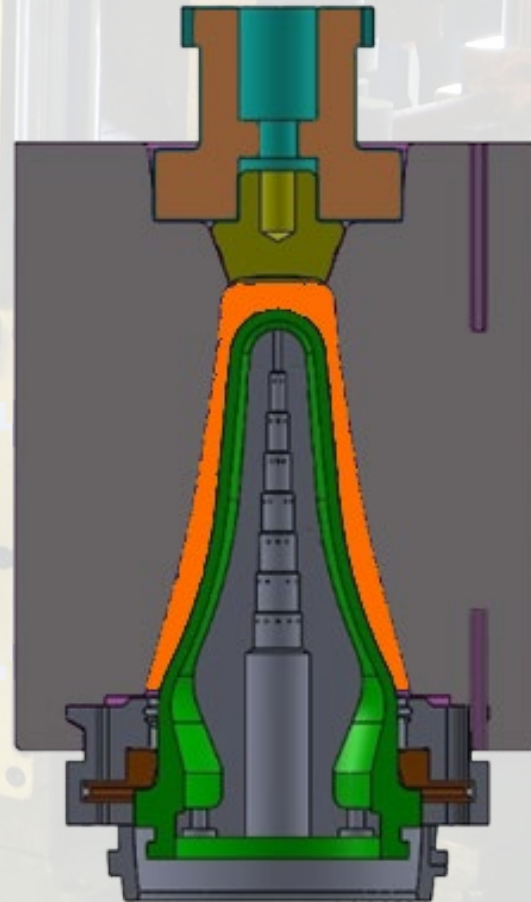

WHO WE ARE



PB / NNPB PROCESS

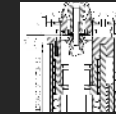

PB / ELEMENTS



GALAXY NRP AW1



LMS V1



PB PROCESS

We know that one of the glass forming processes is the PB process by which the production capacity of the machine can be increased.

One of the first press-and-blow manufacturing processes was the so-called 62 for large mouth process

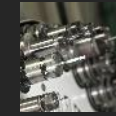
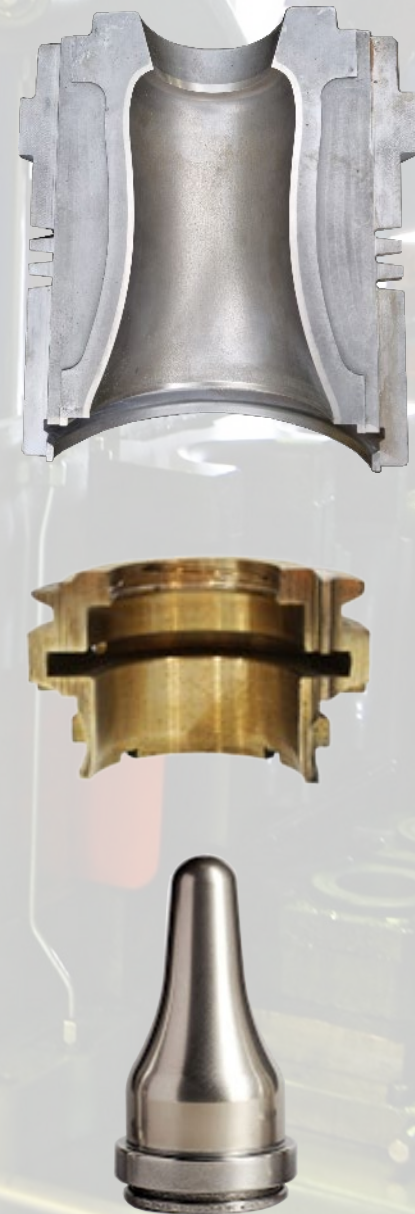

WHO WE ARE



PB / NNPB PROCESS

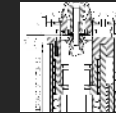

PB / ELEMENTS



GALAXY NRP AW1



LMS V1



NNPB PROCESS

To maximize the potential of the PB process, the narrow-neck press and blow (NNPB) process was developed in the late 1960s as a result of attempts to reduce container weight.

In the production of containers with NNPB system, the plunger plays a key role on the physical redistribution of glass during the forming process.

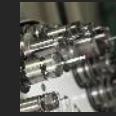
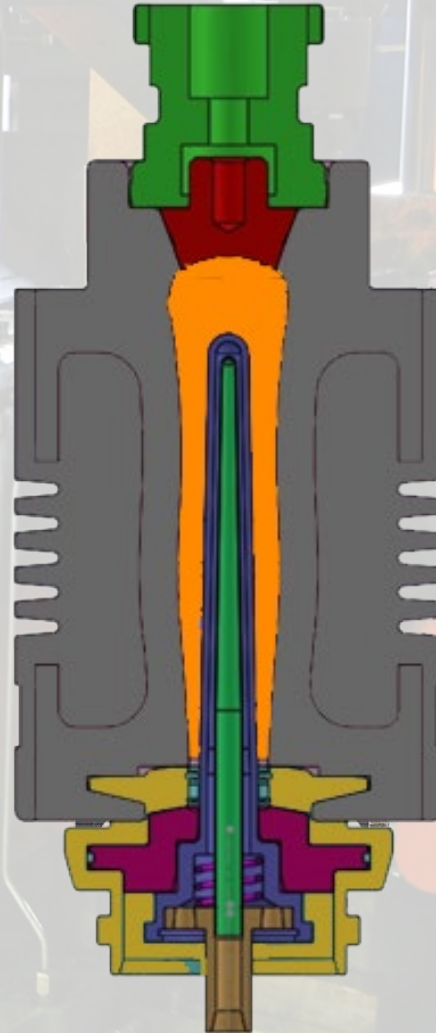

WHO WE ARE



PB / NNPB PROCESS

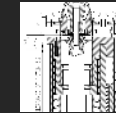

PB / ELEMENTS



GALAXY NRP AW1



LMS V1



NNPB PROCESS

To maximize the potential of the PB process, the narrow-neck press and blow (NNPB) process was developed in the late 1960s as a result of attempts to reduce container weight.

In the production of containers with NNPB system, the plunger plays a key role on the physical redistribution of glass during the forming process.

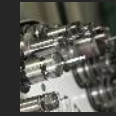

WHO WE ARE



PB / NNPB PROCESS

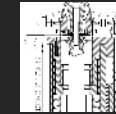

PB / ELEMENTS



GALAXY NRP AW1



LMS V1



The elements



PLUNGER

Is responsible for forming the cavity and controlling as well as distributing the glass within the parison.

Serves as heat exchanger.

It is subject to high wear rates and is directly responsible for product defects.



NECK RING

Is subject to continuous opening and closing movement for the release of the container; this movement results in sliding on the guide ring and this leads to wear that is a harbinger of defects on the mouth of the container.



MOULD

The blank mold, as well as the blow mold, requires continuous maintenance, and the work cycles to which it is subjected cause wear of its inner surface with the consequent increase in cavity volume.



The increase in production speed and the demand for the reduction of defect rates in containers, have led to an increase in demands for mould tooling, and all of this has resulted in an increase in costs related to mold tooling

Continuous monitoring of the operating condition of these elements is essential to prevent container defects

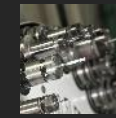

WHO WE ARE



PB / NNPB PROCESS

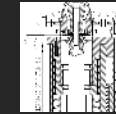

PB / ELEMENTS



GALAXY NRP AW1



LMS V1





GALAXY NRP AW1

Neck rings and plungers
measuring machine



LMS V1

Moulds measuring
machine

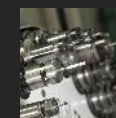

WHO WE ARE



PB / NNPB PROCESS

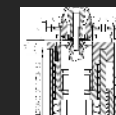

PB / ELEMENTS



GALAXY NRP AW1



LMS V1





GALAXY NRP AW1

Neck rings and plungers
measuring machine

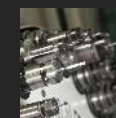

WHO WE ARE



PB / NNPB PROCESS

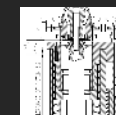

PB / ELEMENTS



GALAXY NRP AW1

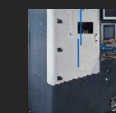

LMS V1



The machine is equipped with two control stations, one for the plungers and the other for the neck rings, with specially designed measuring systems based on laser and touch probe technology.

Specifically, the part that measures the neck rings is made on a **touch probe with a ruby ball** having a diameter of 1 mm and a precision of microns; the part that concerns the plungers, on the other hand, consists of **4 Keyence laser heads** and the system has a repetibility of around 2,5 microns.

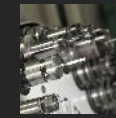
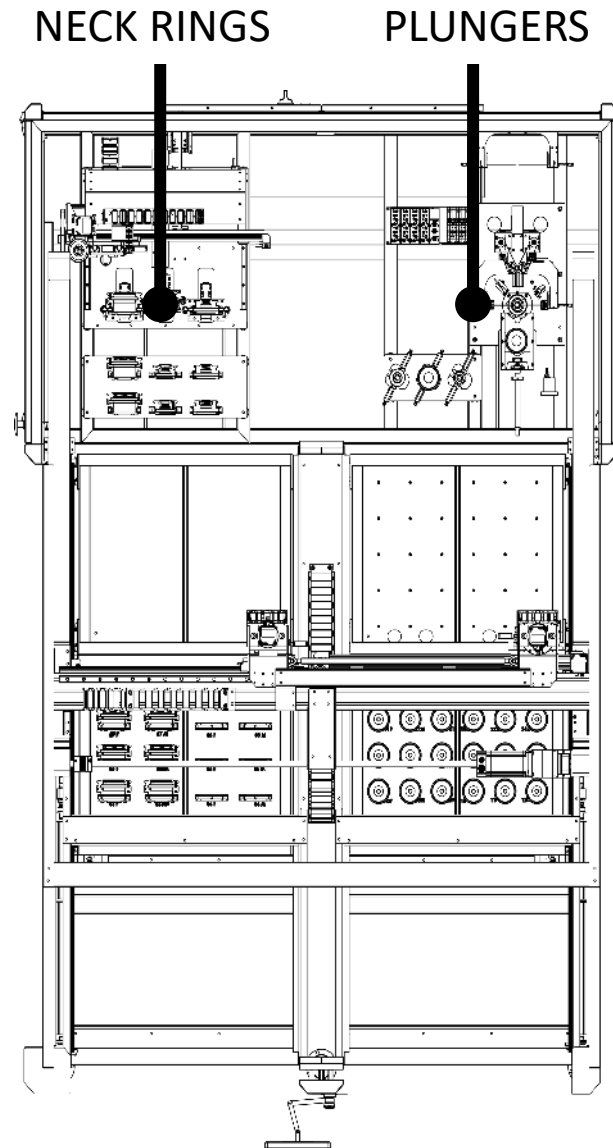

WHO WE ARE



PB / NNPB PROCESS

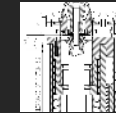

PB / ELEMENTS



GALAXY NRP AW1



LMS V1



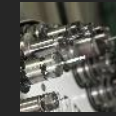
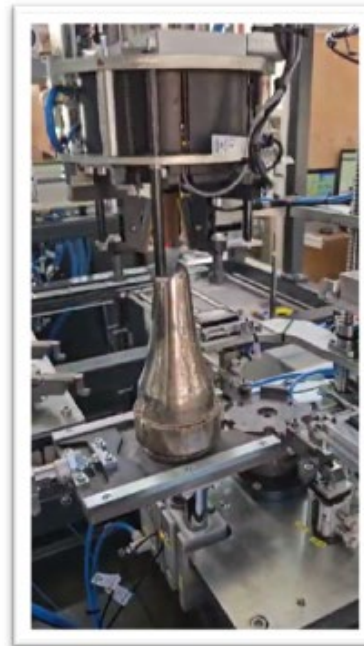
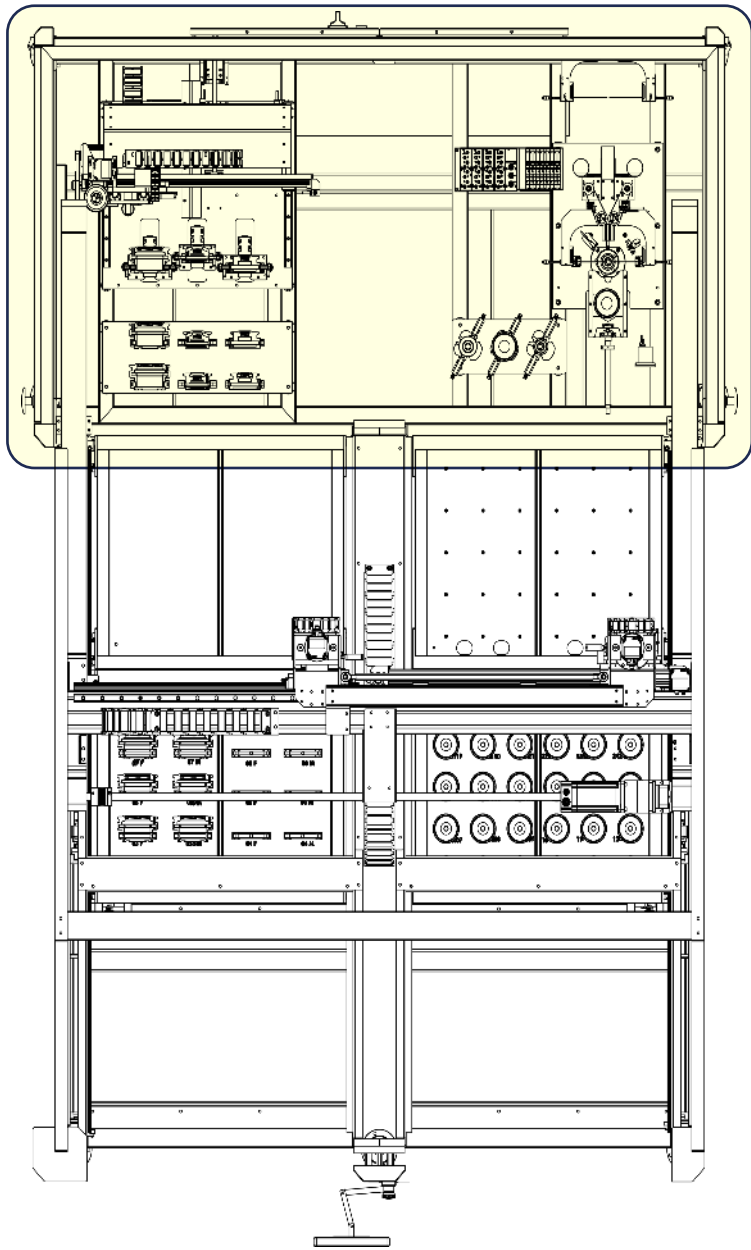

WHO WE ARE



PB / NNPB PROCESS

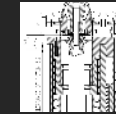

PB / ELEMENTS



GALAXY NRP AW1



LMS V1



The AW1 module enables the NRP machine to perform automatic checks on a predefined number of parts, thus limiting the amount of time spent by the operator on the machine to a minimum. The AW1 automatic magazine is equipped with **trays** with predefined part positioning stations designed to facilitate part positioning by the operator. Once loaded, the **handling system** picks up the items and places them in a double-row parking station to allow faster positioning in the measuring station, reducing cycle times.

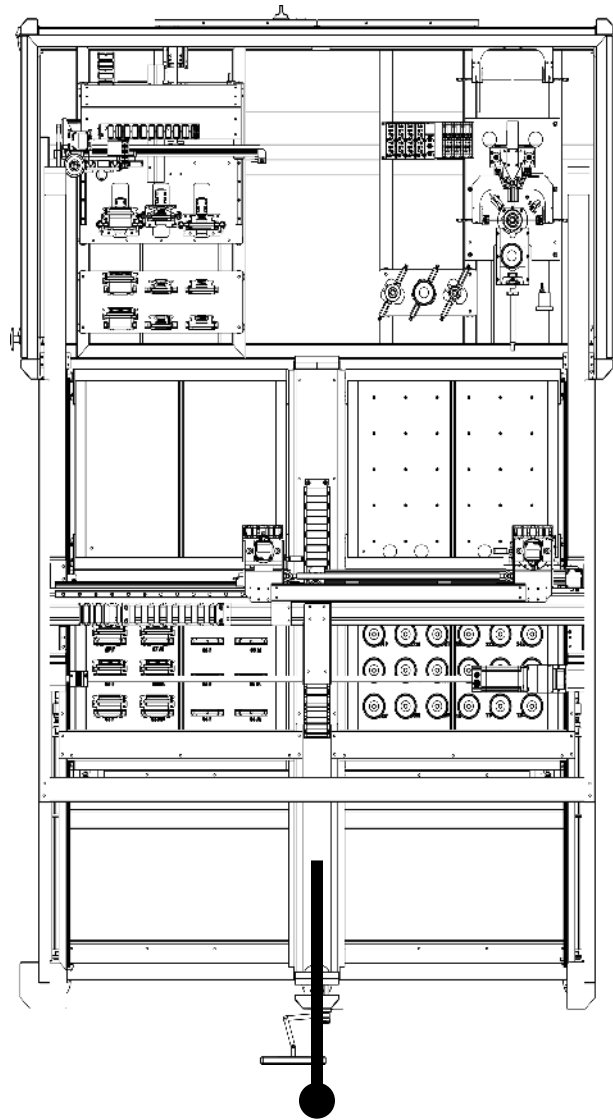

WARE HOUSE AND HANDLING SYSTEM

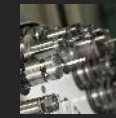

WHO WE ARE



PB / NNPB PROCESS

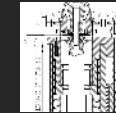

PB / ELEMENTS



GALAXY NRP AW1



LMS V1



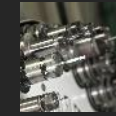
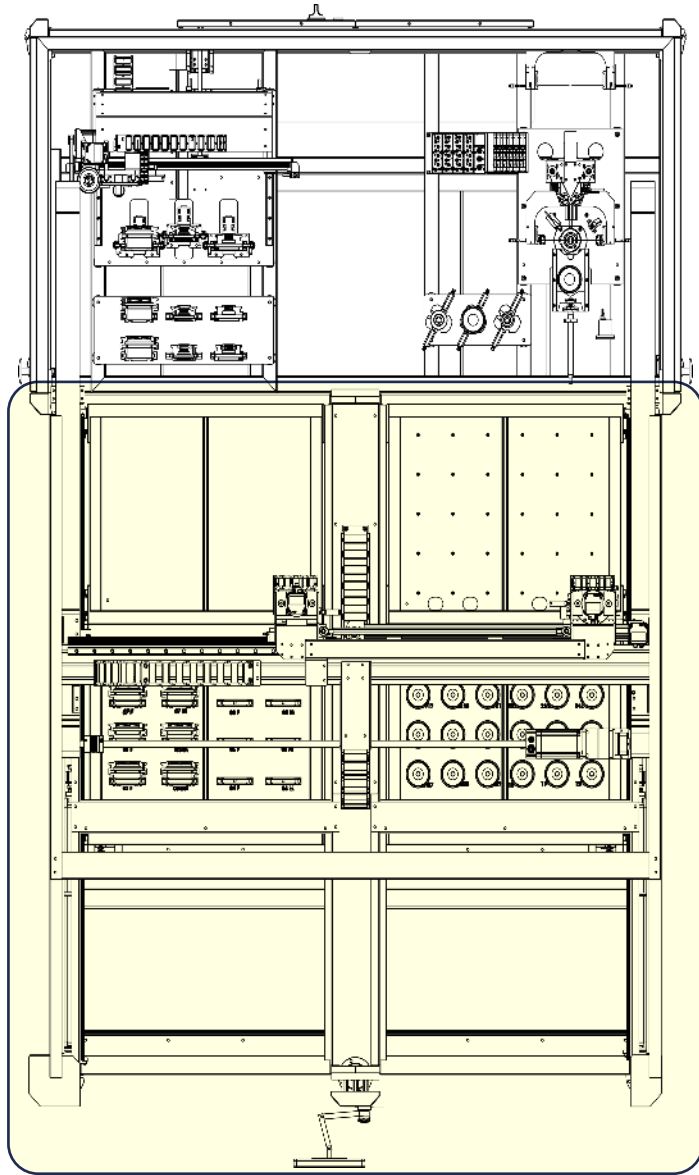

WHO WE ARE



PB / NNPB PROCESS

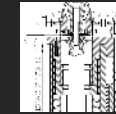

PB / ELEMENTS



GALAXY NRP AW1



LMS V1



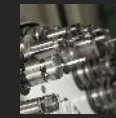

WHO WE ARE



PB / NNPB PROCESS

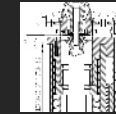

PB / ELEMENTS



GALAXY NRP AW1



LMS V1



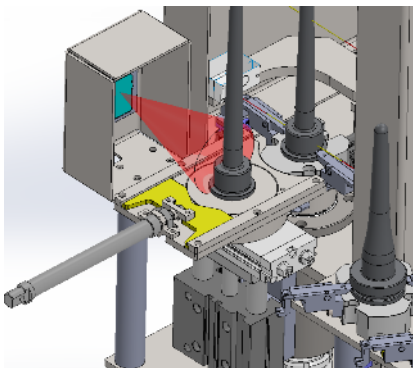

WHO WE ARE



PB / NNPB PROCESS

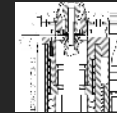

PB / ELEMENTS



GALAXY NRP AW1



LMS V1





LMS V1

Moulds measuring
machine

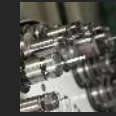

WHO WE ARE



PB / NNPB PROCESS

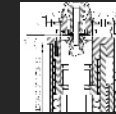

PB / ELEMENTS



GALAXY NRP AW1



LMS V1

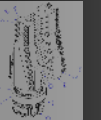

The heart of the machine consists of a **rotary table** where the parts of the mould (the two halves and the baffle/bottom plate) are placed and the Laser Scanning System which houses the **Keyence measuring head**

The table positions the part to be measured in front of the head which scans the part: the part, **rotating on itself**, places its surface in front of the laser head at various angles, allowing a perfect acquisition of all the surface

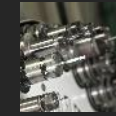
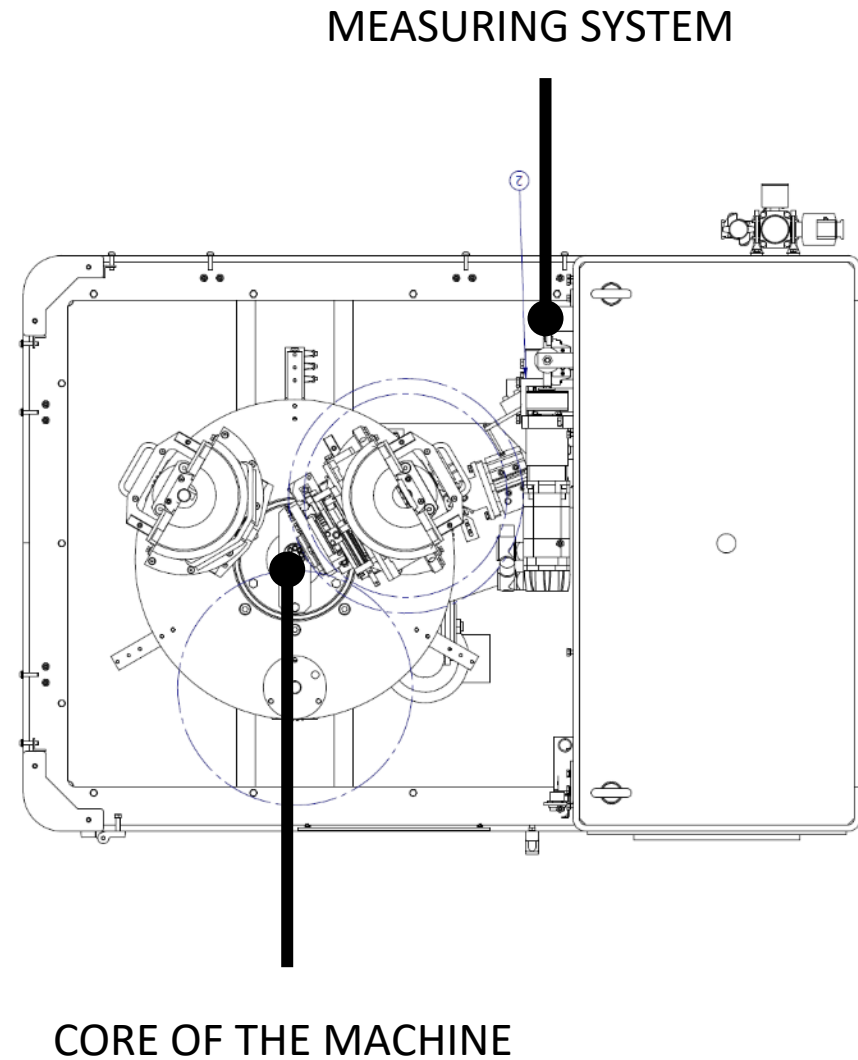

WHO WE ARE



PB / NNPB PROCESS

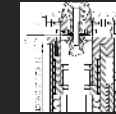

PB / ELEMENTS



GALAXY NRP AW1



LMS V1



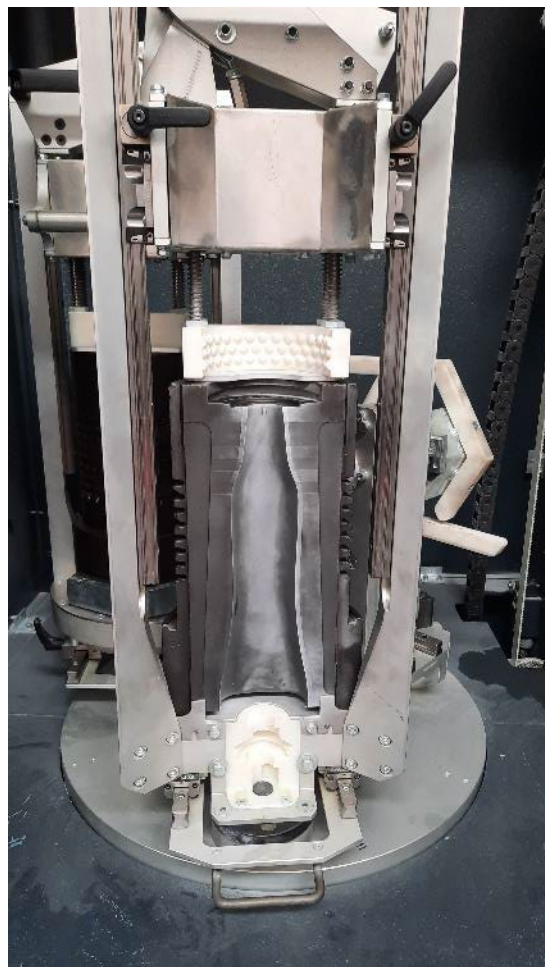
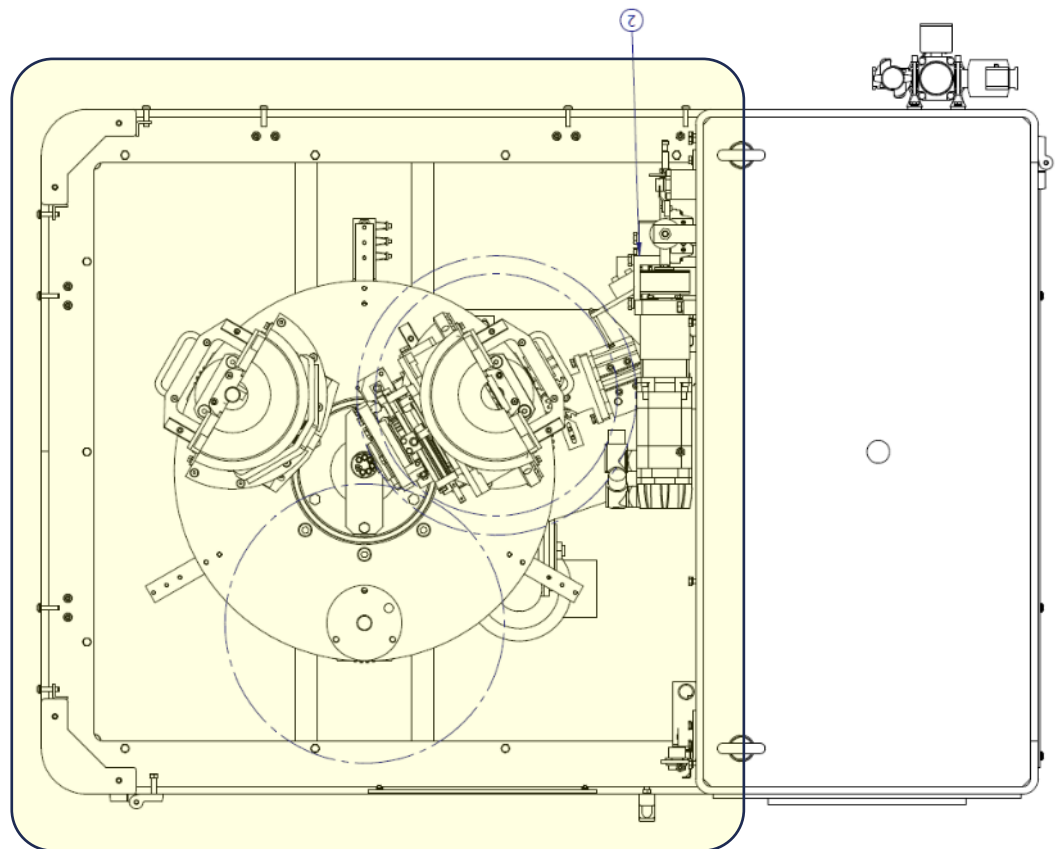

WHO WE ARE



PB / NNPB PROCESS

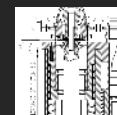

PB / ELEMENTS



GALAXY NRP AW1



LMS V1

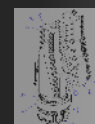

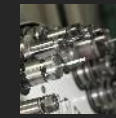
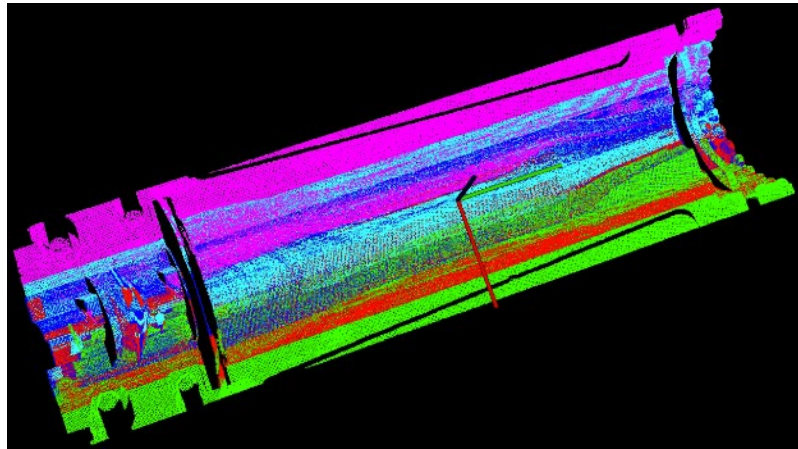
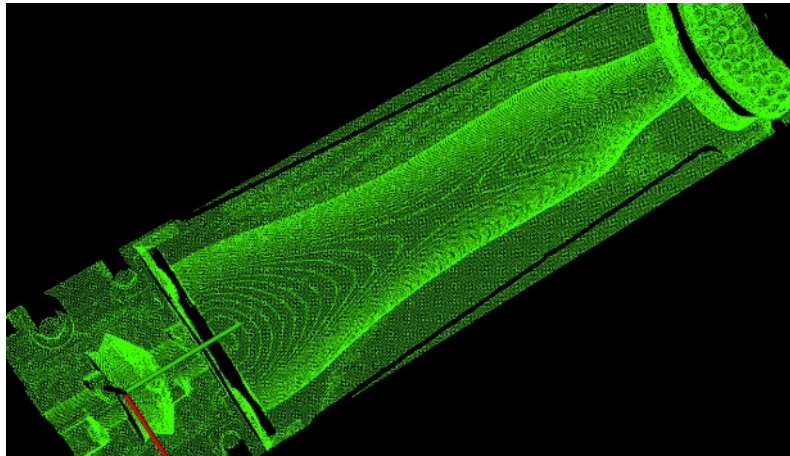

WHO WE ARE



PB / NNPB PROCESS

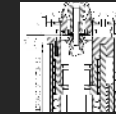

PB / ELEMENTS



GALAXY NRP AW1



LMS V1

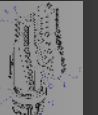

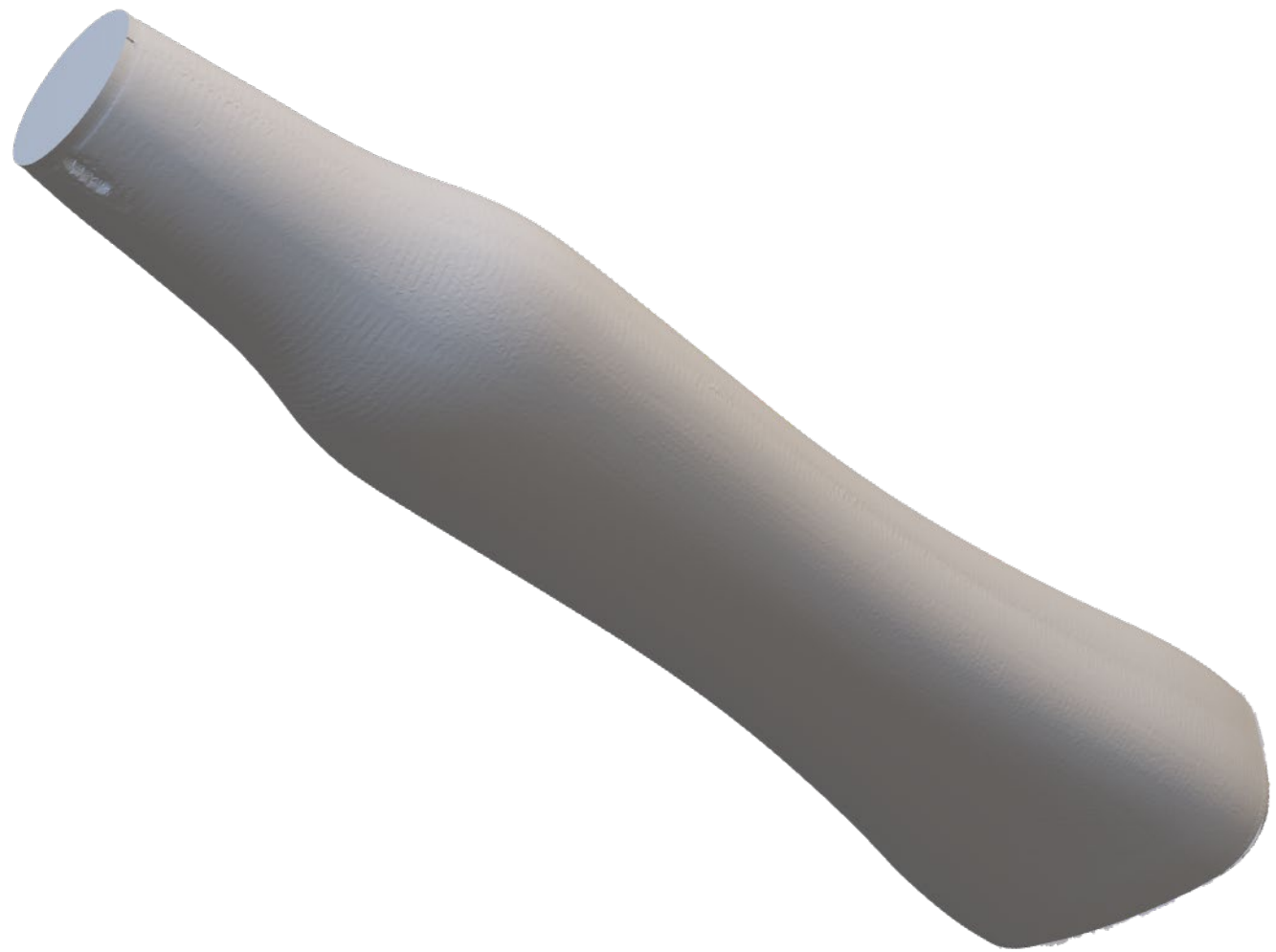

WHO WE ARE



PB / NNPB PROCESS

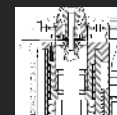

PB / ELEMENTS



GALAXY NRP AW1

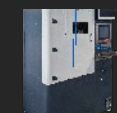

LMS V1

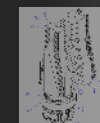

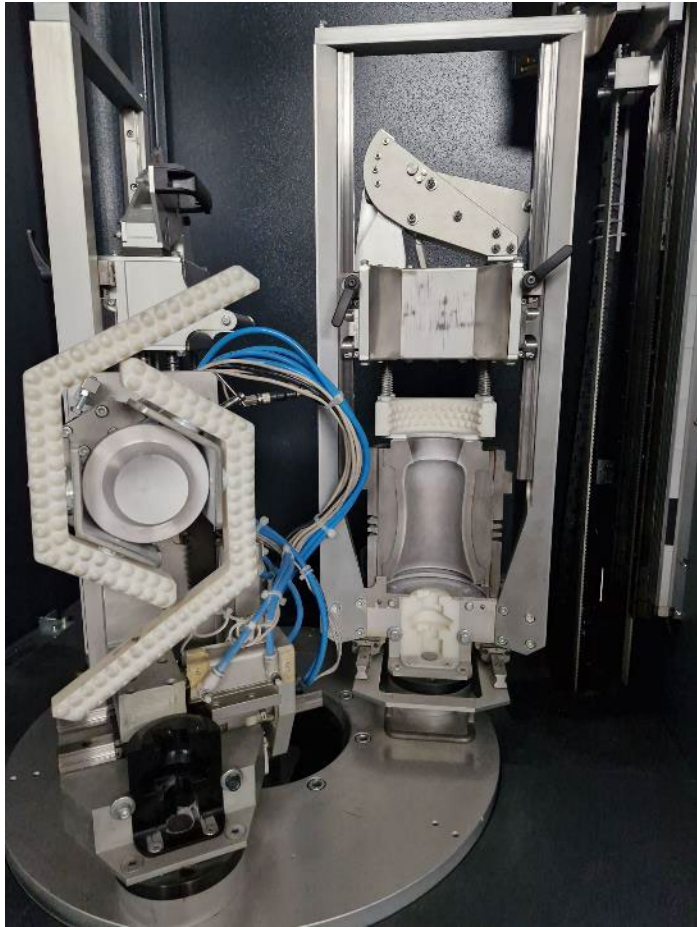

WHO WE ARE



PB / NNPB PROCESS

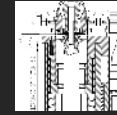

PB / ELEMENTS



GALAXY NRP AW1



LMS V1

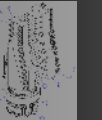



WHO WE ARE



PB / NNPB PROCESS

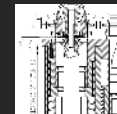

PB / ELEMENTS



GALAXY NRP AW1



LMS V1

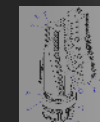

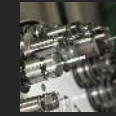
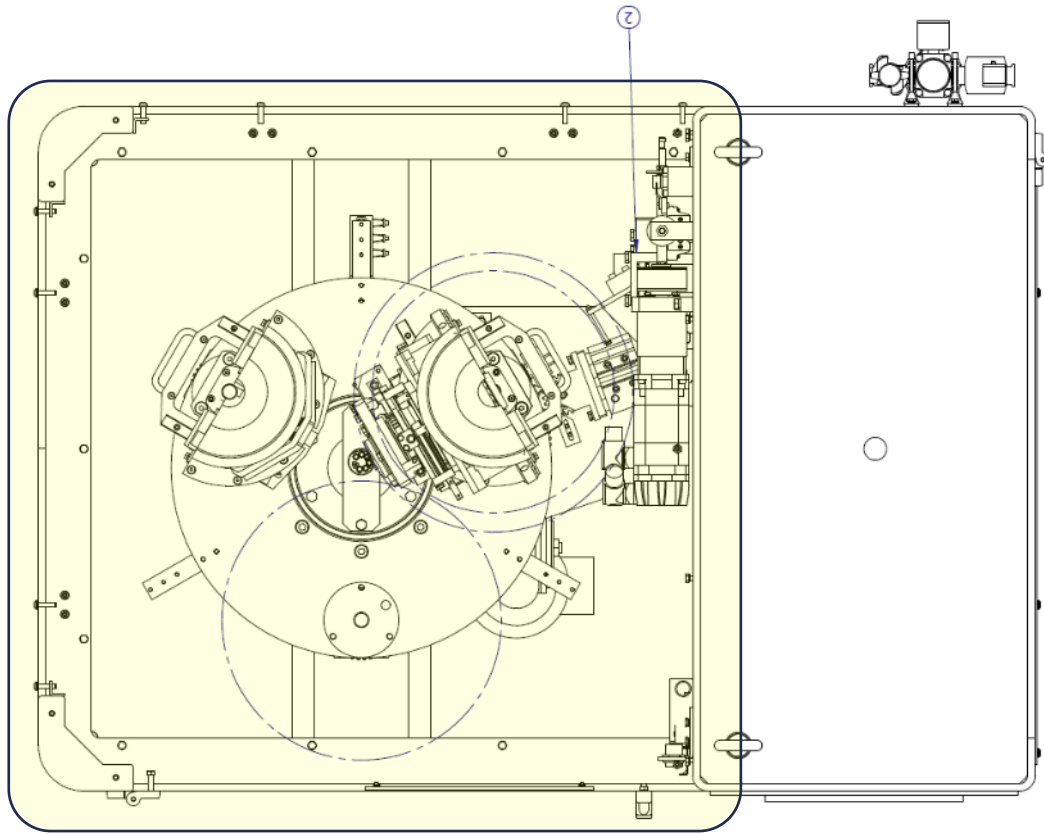

WHO WE ARE



PB / NNPB PROCESS

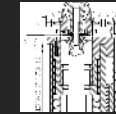

PB / ELEMENTS



GALAXY NRP AW1



LMS V1



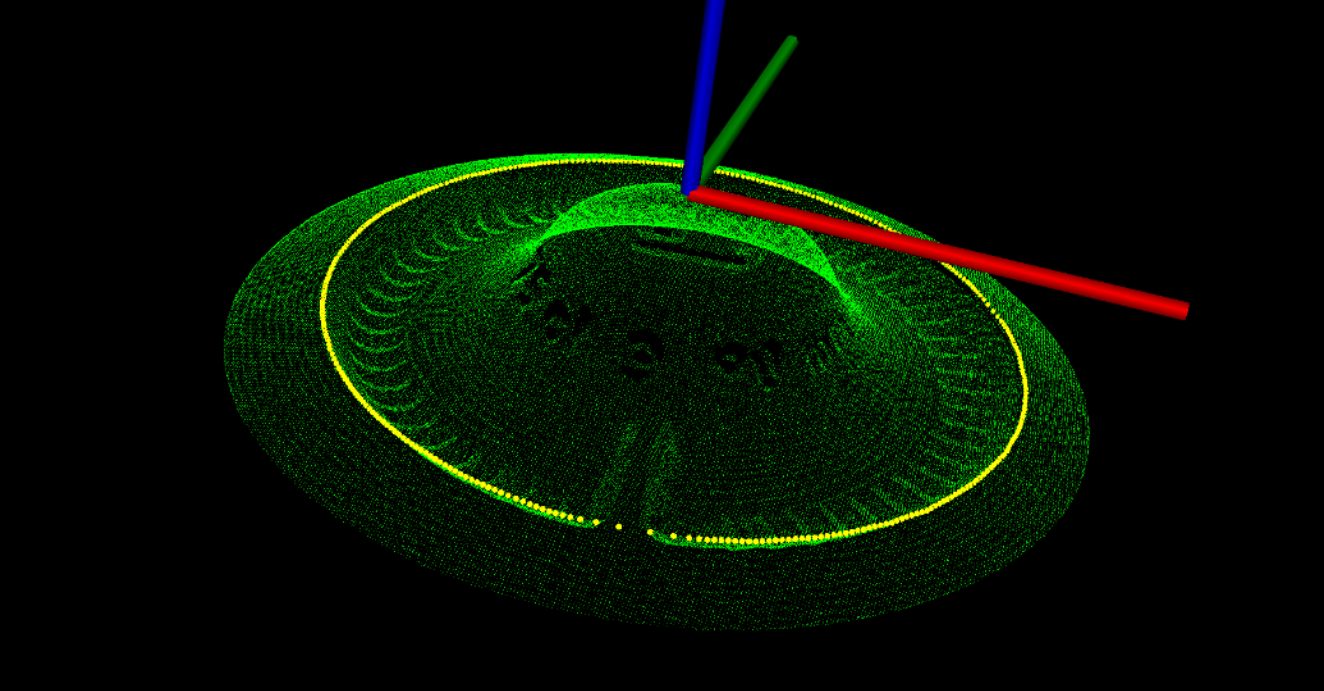
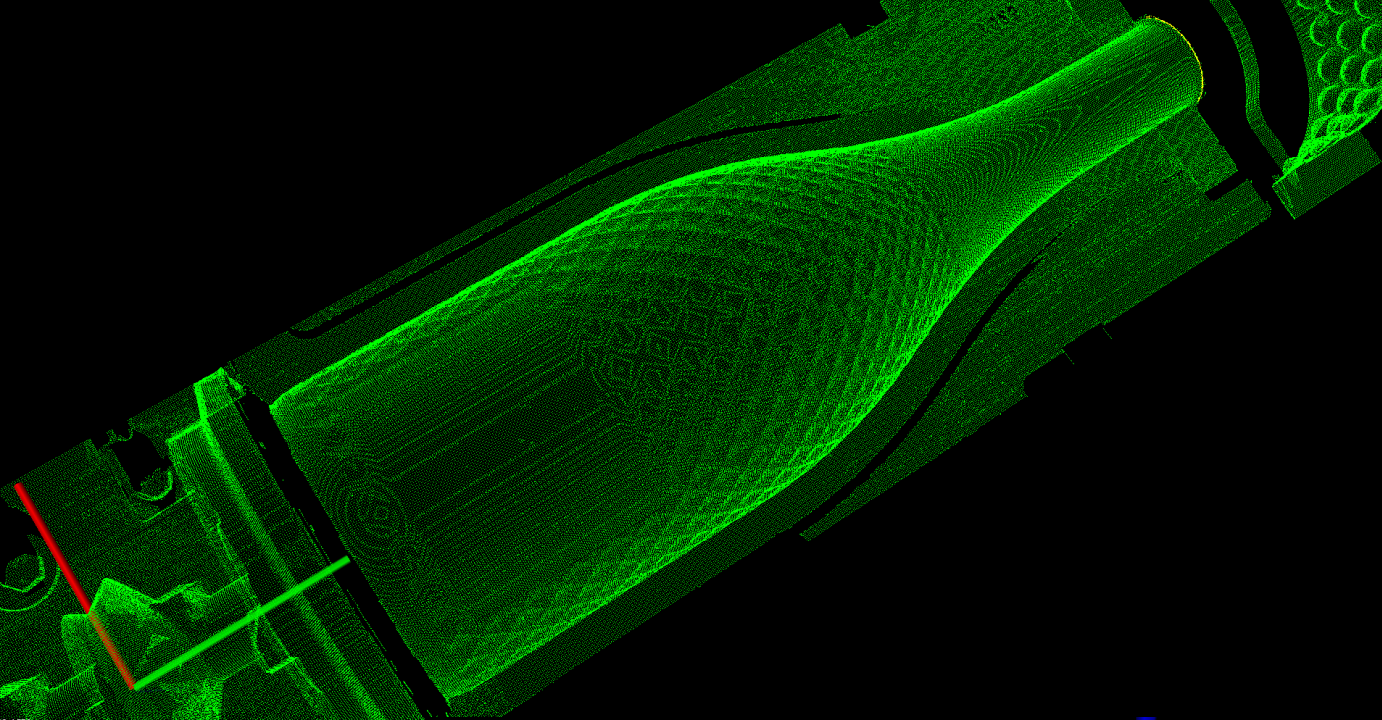

WHO WE ARE



PB / NNPB PROCESS

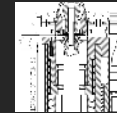

PB / ELEMENTS



GALAXY NRP AW1



LMS V1

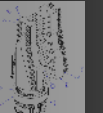

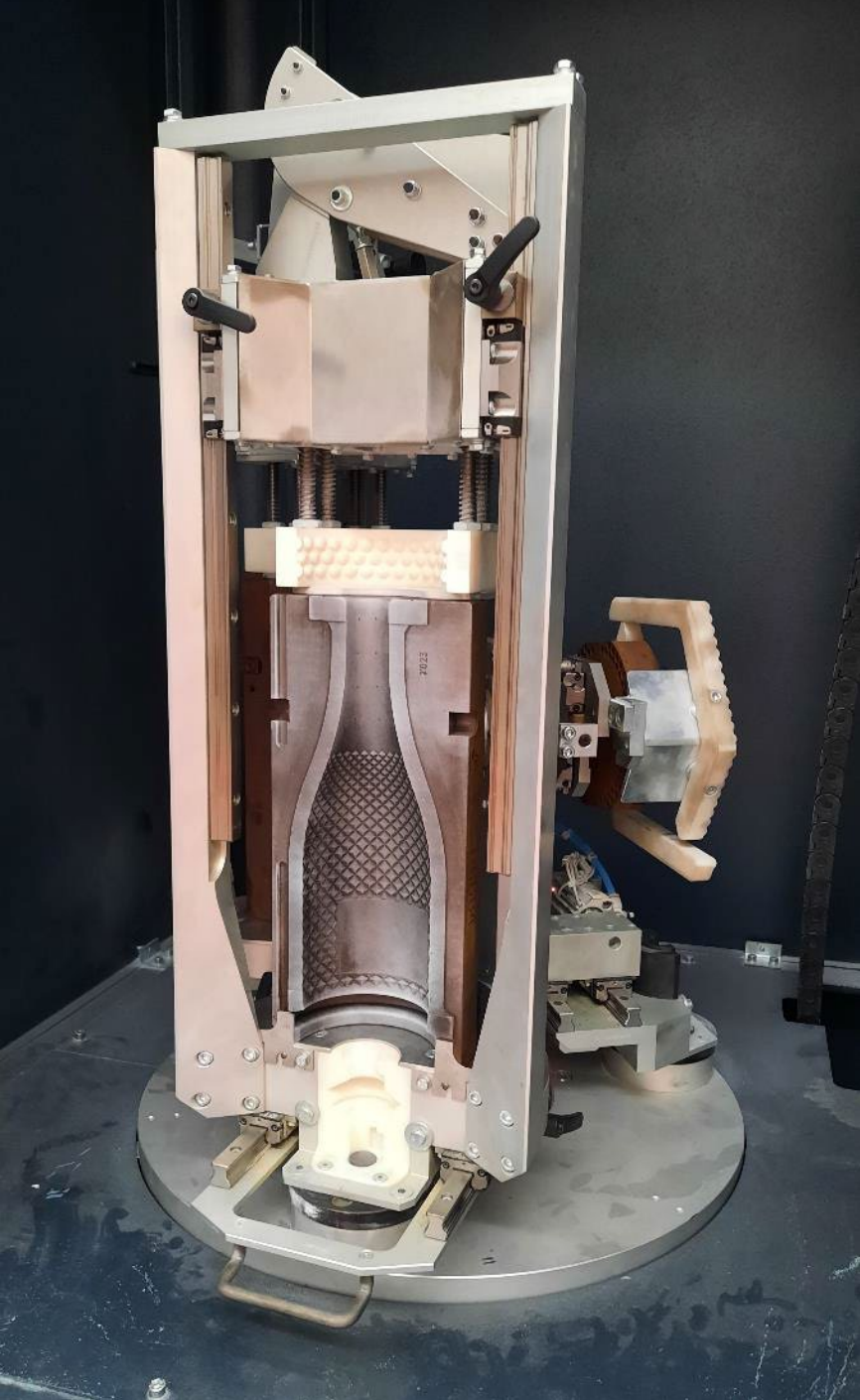

WHO WE ARE



PB / NNPB PROCESS

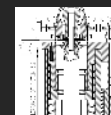

PB / ELEMENTS



GALAXY NRP AW1



LMS V1

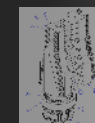

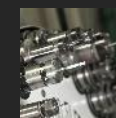

WHO WE ARE



PB / NNPB PROCESS

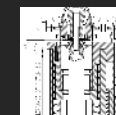

PB / ELEMENTS



GALAXY NRP AW1



LMS V1

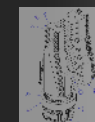

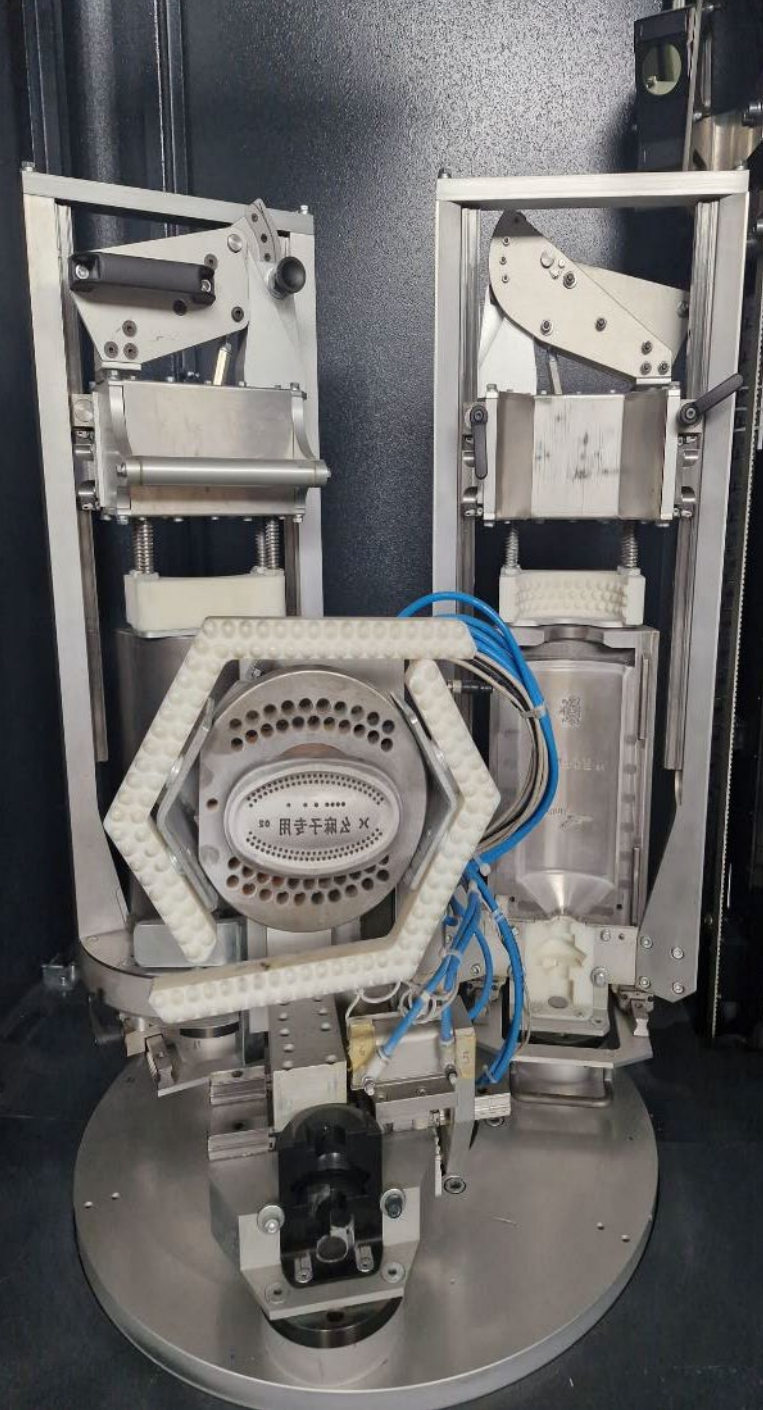

WHO WE ARE



PB / NNPB PROCESS

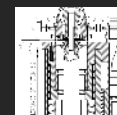

PB / ELEMENTS



GALAXY NRP AW1



LMS V1

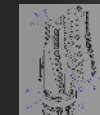



WHO WE ARE



PB / NNPB PROCESS

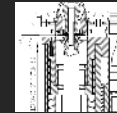

PB / ELEMENTS



GALAXY NRP AW1



LMS V1

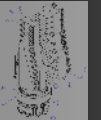

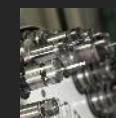

WHO WE ARE



PB / NNPB PROCESS

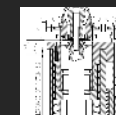

PB / ELEMENTS



GALAXY NRP AW1



LMS V1

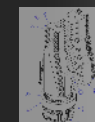

CONCLUSION

Checking the dimensions of the components is an operation that is carried out to assess the suitability of them for production.

In fact, **if the volume of the mould increases**, the amount of glass needed to make the same container will also increase, resulting in higher costs.

Wear of the neck ring and guide ring result in major and dangerous defects on the mouth of the container

Last but not least, **a non perfect dimensional condition of the plunger** (verticality and diameters) results in the forming of defective articles and therefore to be discarded

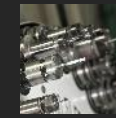

WHO WE ARE



PB / NNPB PROCESS

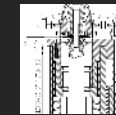

PB / ELEMENTS



GALAXY NRP AW1



LMS V1





**THANK YOU
FOR
YOUR ATTENTION**

LUBEN GLASS S.r.L.
Via A. Meucci, 23
26013 Offanengo (CR)
ITALY

www.lubenglass.eu

